

Starlink™ Standard DC Conversion

Eliminate the Starlink™ AC power supply and router, conserve power with the DishyNOAC, using native DC power and avoiding inverter losses.

This conversion includes replacing the Starlink™ router with an AX1800 router featuring a 1 Gbps (1000 Mbps) WAN Ethernet port.

An optional 4G/5G-enabled router can be used for “failover” connectivity when Starlink™ is turned off.

Inline Power Switch alternative: Consider fitting a relay for convenient switching or switch via control system such as Victron Cerbo and avoid longer than necessary cable runs. See Starlink™ Standard DC Relay Conversion and Starlink™ Standard DC Relay Cerbo Conversion.

Installation guide: <http://strvm.uk/noac>

DC POWER SOURCE 200Ah Minimum
Details: <http://strvm.uk/noac#power>

POWER CABLE 2.5mm² Minimum
Details: <http://strvm.uk/noac#power>

DishyNOAC FUSE 15A
Details: <http://strvm.uk/noac#fuse>

WIFI ACCESS POINT
Details: <http://strvm.uk/noac#wifi>

GROUNDING
Details: <http://strvm.uk/noac#grounding>

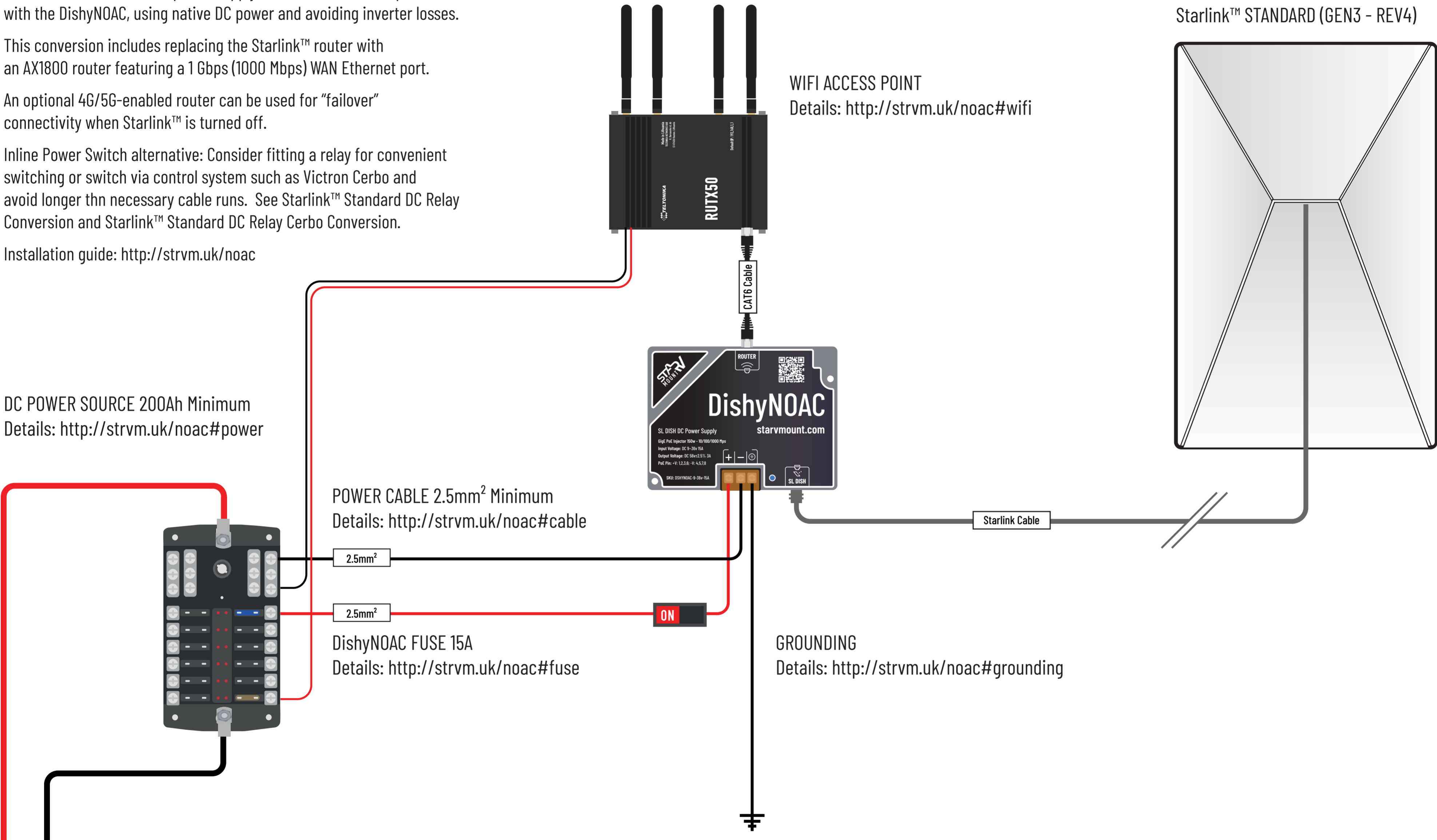

CAUTION
Schematic for guidance only. Please verify against manufacturer manuals.
When fitting, undertake your own risk assessment regarding placement and attachment.
Always be considerate of others and your own safety.
Starmount™ products are intended for installation by telecommunications professionals or other similarly technically experienced users.
Starmount™ does not accept any liability for installation work